

PRODUCT INFORMATION PACKET



Model No: 215TTTN16537A

Catalog No: 824531.00

..10HP..1800RPM.215T.TEAO.230/460V.3PH.60HZ.AIR OVER.40C.1.15SF.RIGID BASE.....COOLING
TOWER

Cooling Tower



Regal and Leeson are trademarks of Regal Beloit Corporation or one of its affiliated companies.

©2018 Regal Beloit Corporation, All Rights Reserved. MC017097E





Nameplate Specifications

Output HP	10 Hp	Output KW	7.5 kW
Frequency	60 Hz	Voltage	230/460 V
Current	25.0/12.5 A	Speed	1765 rpm
Service Factor	1.15	Phase	3
Efficiency	91.7 %	Duty	Continuous
Insulation Class	F	Design Code	B
KVA Code	G	Frame	215T
Enclosure	Totally Enclosed Air Over	Overload Protector	No
Ambient Temperature	40 °C	Drive End Bearing Size	6307
Opp Drive End Bearing Size	6208	UL	No
CSA	N	CE	N
IP Code	55		

Technical Specifications

Electrical Type	Squirrel Cage Inverter Rated	Starting Method	Line Or Inverter
Poles	4	Rotation	Reversible
Mounting	Rigid base	Motor Orientation	HORIZONTAL
Drive End Bearing	BALL	Opp Drive End Bearing	BALL
Frame Material	Cast Iron	Shaft Type	T
Overall Length	20.47 in	Frame Length	12.12 in
Shaft Diameter	1.375 in	Shaft Extension	3.38 in
Assembly/Box Mounting	F1/F2 CAPABLE		
Outline Drawing	038188-1212	Connection Diagram	A-EE7308-LE

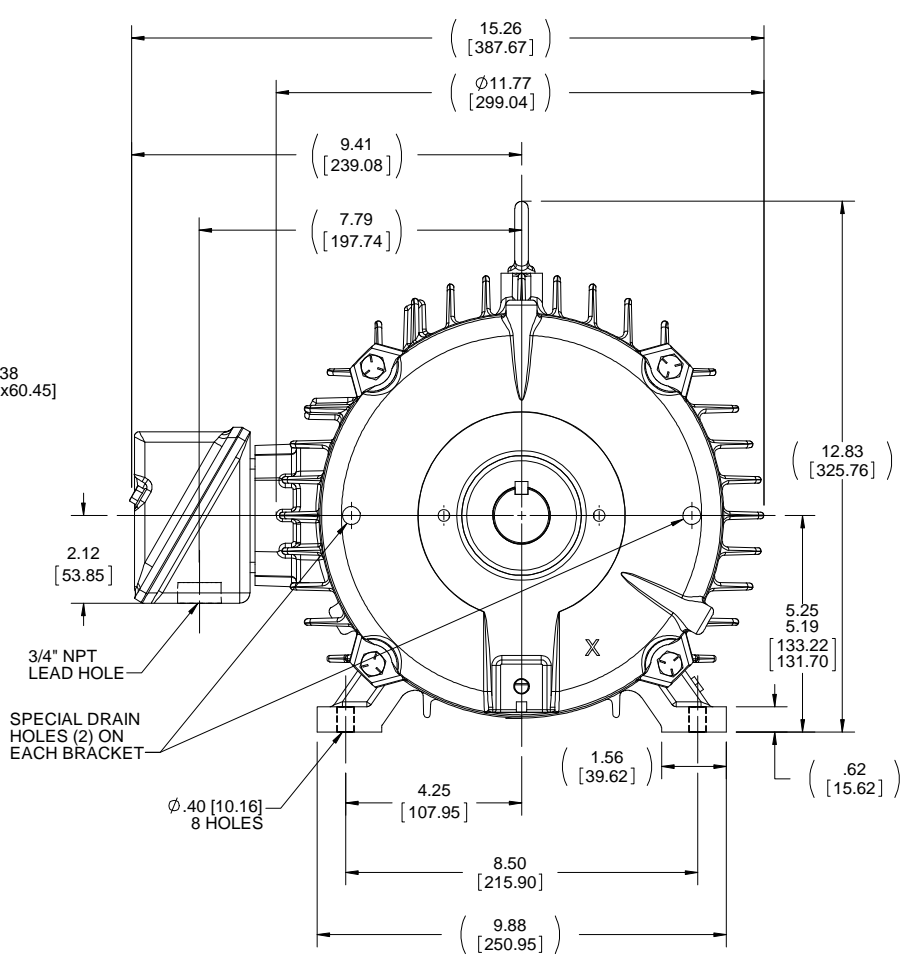
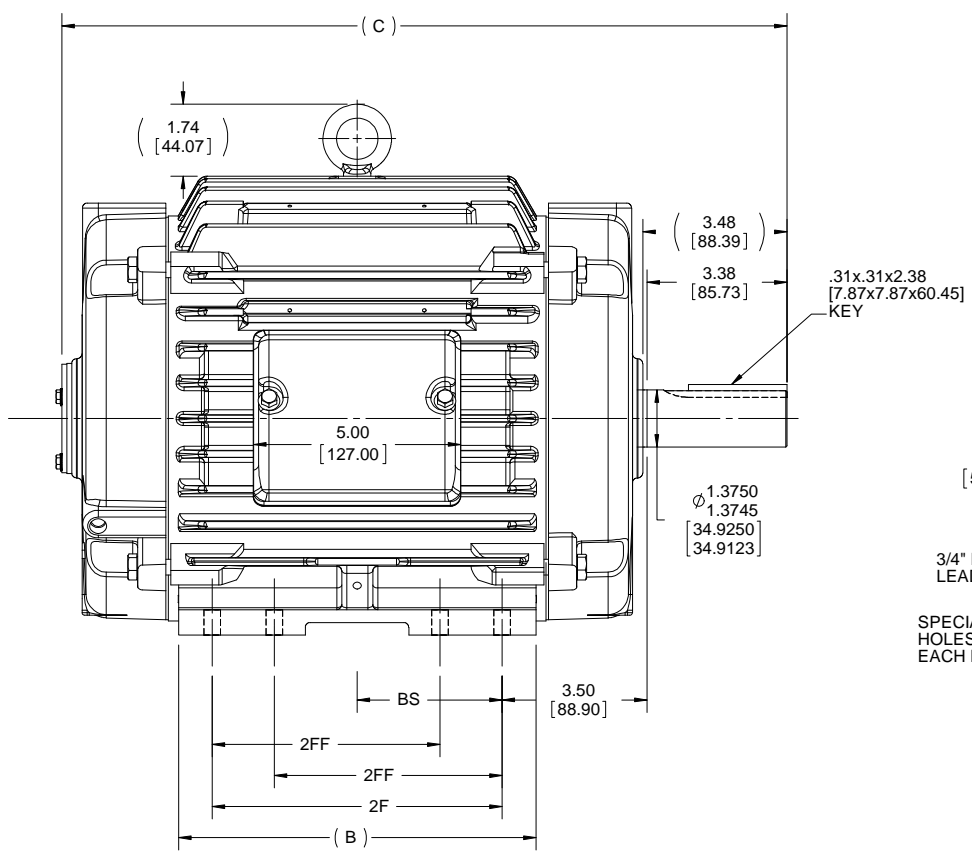

- NOTES:
1. CONDUIT BOX CAN BE ROTATED IN 90° STEPS.
 2. CONDUIT BOX CAN BE MOUNTED IN OPPOSITE SIDE BY REMOVING BRACKETS AND TURNING FRAME 180°.
 3. NAMEPLATE TO BE READ FROM CONDUIT BOX SIDE OF MOTOR.

1212	215	20.51 [520.95]	11.76 [298.70]	10.00 [254.00]	7.00 [177.80]	5.00 [127.00]
912	213/215	17.51 [444.75]	8.63 [219.20]	7.00 [177.80]	5.50 [139.70]	3.50 [88.90]
DASH	FRAME	C	B	2F	2FF	BS

DRAWING REVISION A	REVISION BY MVG	DATE 10/10/2017
ECO ECO-0128141	APPROVED BY ST	DATE 10/10/2017
ECO DESCRIPTION NEW DRAWING		
<small>COPYRIGHT REGAL BELOIT AMERICA, INC. ALL RIGHTS RESERVED. PROPRIETARY AND CONFIDENTIAL INFORMATION - THIS DOCUMENT IS THE PROPERTY OF REGAL BELOIT AMERICA, INC. ("OWNER") AND CONTAINS OWNER'S PROPRIETARY INFORMATION. ANY PERSON, CORPORATION OR OTHER FIRM RECEIVING IT IS DEEMED, BY RECEIVING IT, TO AGREE THAT IT, AND/OR ANY PART OF IT, SHALL NOT BE DISCLOSED TO ANY PERSON, CORPORATION OR OTHER ENTITY, DUPLICATED, AND/OR USED, EXCEPT AS EXPRESSLY APPROVED IN WRITING IN ADVANCE BY OWNER. THIS DOCUMENT SHALL BE RETURNED TO OWNER UPON REQUEST. IT MAY BE SUBJECT TO CERTAIN RESTRICTIONS UNDER APPLICABLE EXPORT CONTROL LAWS AND REGULATIONS.</small>		

TOLERANCES UNLESS OTHERWISE SPECIFIED:

DEC.	INCH	mm	ANGLE
X	+0.1	[+2.5]	$\pm 0.5^\circ$
.XX	+0.03	[+0.76]	
.XXX	+0.005	[+0.127]	
.XXXX	+0.0005	[+0.0127]	

REMOVE BURRS & BREAK SHARP EDGES: .003/.015 [0.076/.381] X 45°
 CORNER FILLETS: R.02 [51]
 MACHINED SURFACES: 125/3.2 INCH/mm

DRAWN BY MVG	DATE 10/10/2017
APPROVED BY ST	DATE 10/10/2017
REFERENCE 013907	THIRD ANGLE PROJECTION

REGAL™ Regal Beloit America, Inc.

DESCRIPTION
OUTLINE
210 FR-STD-STD-T-TENV

MATERIAL
PROCESS/FINISH

SIZE
B

DRAWING NUMBER
038188

SHEET
1 OF 1

THREE PHASE
DUAL VOLTAGE MOTOR

HIGH VOLTAGE

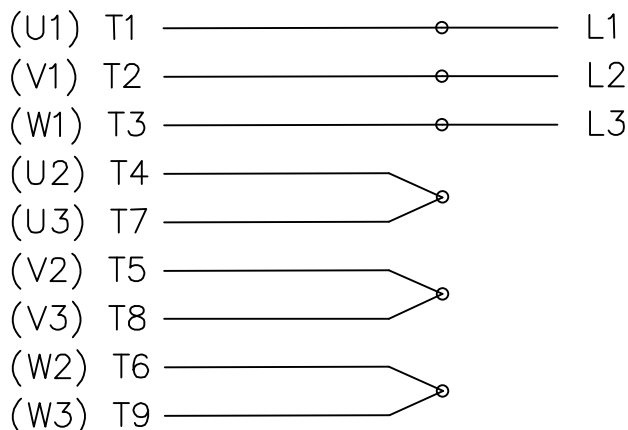

LOW VOLTAGE

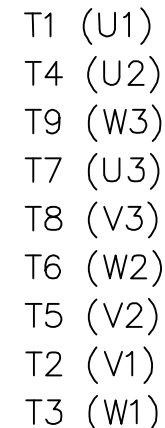
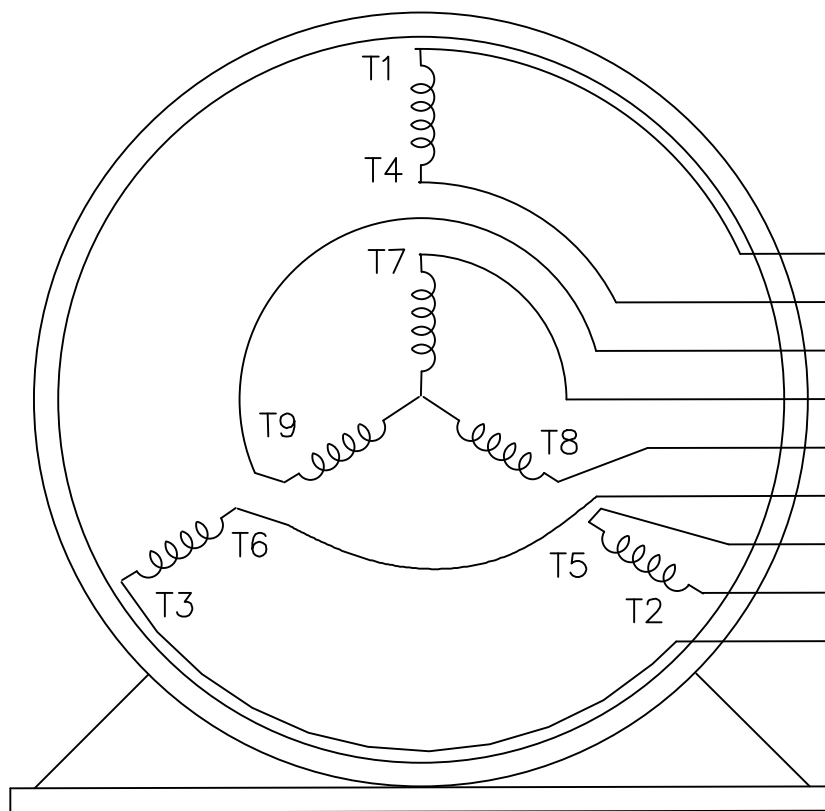
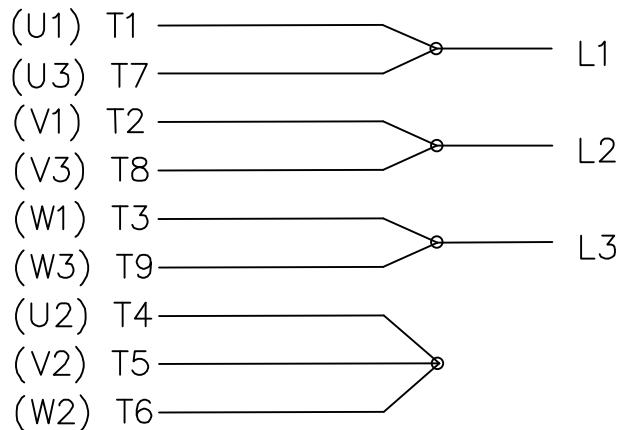

VIEW OF TERMINAL END

REF.
WINDING DIAGRAM

T8Y, T2Y, T2BL, T4BX, T2EC, T2G
T6BZ, T2B, T6BL, T4AV, T6B, T4B

				TOLERANCES UNLESS SPECIFIED		 ELECTRIC MOTORS GEARMOTORS AND DRIVES	DRAWN HLB 04-29-2002	
				DEC.	INCHES		CHK	ML 05-03-2002
				.X	±.1		APPD	GK 05-03-2002
				.XX	±.01		SCALE	1=1
2	ADDED IEC NOTATIONS... (U1), (V1) ETC. (MU105786)	REP 01-11-2012	DR	.XXX	±.005	TITLE CONNECTION DIAGRAM 3Ø - DUAL VOLTAGE MOTOR		REF
1	NEW DRAWING	HLB 05-03-2002	ML	.XXXX	±.0005	MAT'L.		FMF
NO.	REVISION	BY & DATE	CHK	ANG	±1/2'	FINISH		PREV
THIS DRAWING IN DESIGN AND DETAIL IS OUR PROPERTY AND MUST NOT BE USED EXCEPT IN CONNECTION WITH OUR WORK ALL RIGHTS OF DESIGN AND INVENTION ARE RESERVED THIS IS AN ELECTRONICALLY GENERATED DOCUMENT - DO NOT SCALE THIS PRINT				RFP	CAD FILE EE7308-LE		SIZE	DRAWING NO. PAGE OF REV.
				DIST	LB-WP	A	EE7308-LE	2



Motor Load Data						
Load	0%	25%	50%	75%	100%	LR
Current (Amps)	5.0	5.5	7.5	10.0	12.5	80.0
Torque (ft-lb)	0.00	7.5	14.5	22.0	29.8	60.0
RPM	1800	1790	1785	1775	1765	0
Efficiency (%)		87.5	91.0	91.7	91.7	
P.F. (%)	6.5	47.0	88.0	78.0	82.0	42.0

Motor Speed Data						Information Block																					
Speed (RPM)	LR	Pull-Up	BD	Rated	Idle	HP	Sync. RPM	Frame	Enclosure	Construction	Voltage	Frequency	Design	LR Code letter	Service Factor	Temp Rise @ FL	Duty	Ambient	Elevation	Rotor/Shaft wk ²	Ref Wdg	Sound Pressure @ 1M	VFD Rating	Outline Dwg	Conn. Diag	Additional Specifications:	
0		900	1675	1765	1800	10.0	1800	215	TEAO	TTN	230/460	60	B	G	1.15	0	CONT	40 °C	1,000	1.20	R25	999	VARIABLE 10:1	037875LE-1212	A-EE7308-LE		
Current (Amps)	80.0	72.0	46.0	12.5	5.0																						
Torque (ft-lb)	60.0	54.0	81.0	29.8	0.00																						

EQUIV CKT (OHMS / PHASE)					
R1	R2	X1	X2	Xm	
0.5400	0.4880	2.0930	3.2090	51.1200	

